

Inserta Products, Inc.

CHECK VALVE BODIES WITH SUPPORT MEMBER FLANGE TYPE

INSERTA® ICFS Check Valve Bodies, Flange Type, with their Support Members provide a simple way to install the same nominal size Check Valve or Fixed Orifice Flow Control Valve in a piping system that uses SAE 4-Bolt flange patterns. These bodies accept the INSERTA® ICS Slip-In Type Check Valves, which should be ordered separately. The support member retains the slip-in check valve in the flange body together with the required sealing O-rings. These valve assemblies can be installed on pumps, valves, manifolds and other components that have SAE 4-Bolt ports. The leak resistant O-ring face sealed joint eliminates less desirable pipe connections. The INSERTA® ICS Check Valves, Slip-In Type, can be installed with free flow in either direction.

INSERTA® ICFS Check Valve Bodies, Flange type, with their Support Members are all steel construction.

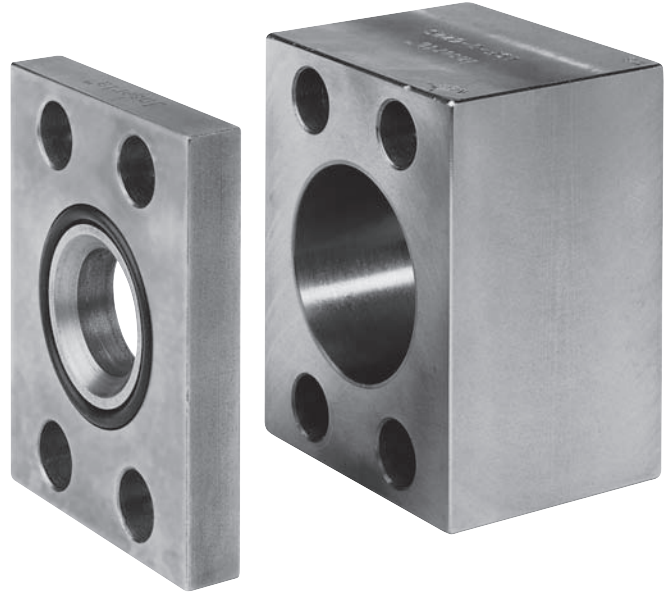

Patent No. 6,776,439 B2

ORDERING INFORMATION

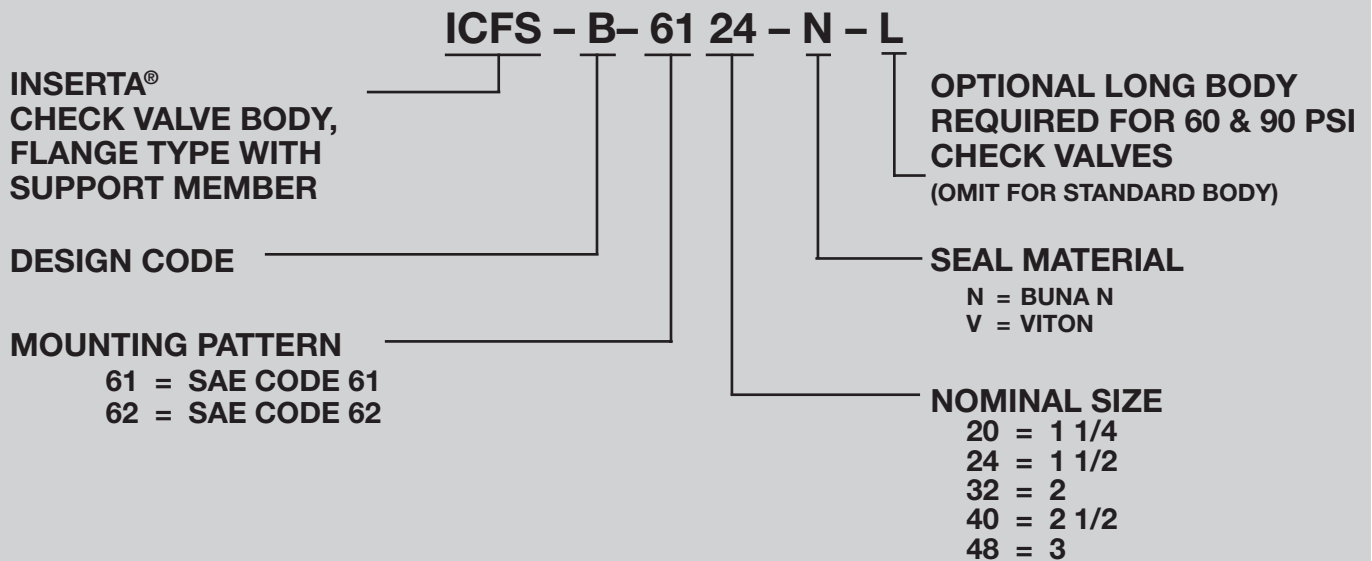

Inserta Products, Inc.
Blue Bell, Pa. 19422

CHECK VALVE BODIES WITH SUPPORT MEMBER FLANGE TYPE



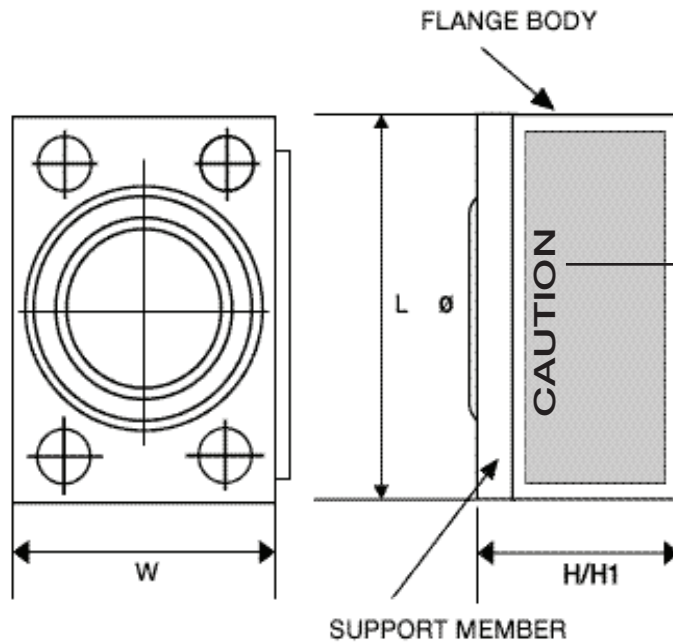

CAUTION
 Care must be exercised when installing check valve to insure the free flow path of the slip-in check valve is correct for the system in which it is installed.

SAE CODE 61

MOUNTING PATTERN - SIZE	NOMINAL SIZE	NOM. FLOW RATE (GPM)	W	H	H ₁ *	L	SLIP-IN CHECK VALVE PART NO.	O-RING SIZE NO.
6120	1 1/4	75	2.25	2.25	3.00	3.00	ICS-C-20-***	222
6124	1 1/2	110	2.50	2.75	3.25	3.75	ICS-C-24-***	225
6132	2	200	3.25	3.50	4.25	4.00	ICS-C-32-***	228
6140	2 1/2	300	3.50	4.25	4.50	4.50	ICS-C-40-***	232
6148	3	400	4.00	4.25	5.00	5.00	ICS-C-48-***	237

SAE CODE 62

MOUNTING PATTERN - SIZE	NOMINAL SIZE	NOM. FLOW RATE (GPM)	W	H	H ₁ *	L	SLIP-IN CHECK VALVE PART NO.	O-RING SIZE NO.
6220	1 1/4	75	2.50	2.50	3.25	3.50	ICS-C-20-***	222
6224	1 1/2	110	3.00	2.75	3.25	4.25	ICS-C-24-***	225
6232	2	200	3.50	3.75	4.50	5.00	ICS-C-32-***	228
6240	2 1/2	300	4.25	4.25	4.50	6.00	ICS-C-40-***	232
6248	3	400	5.00	4.25	5.00	8.00	ICS-C-48-***	237

NOMINAL FLOW RATINGS SHOWN ARE WITH A Δ P OF 20 TO 40 PSI WITH ICS CHECK VALVE INSTALLED. In applications where the valve is subject to sudden shock opening or closing (e.g. Accumulator System), the nominal rated flow must not be exceeded and a minimum cracking pressure of 15 PSI is required. THE PRESSURE RATING OF THESE VALVE ASSEMBLIES MAY BE LIMITED BY THE ICS CHECK INSERT. REFER TO THE ICS DATA SHEET.

OPERATING MEDIUM:
 HYDRAULIC FLUID
 VISCOSITY RANGE:
 50 SSU TO 2000 SSU
 CRACKING PRESSURE:
 3 PSI, 7 PSI, 15 PSI (STANDARD) OR 30 PSI.
 * 60 PSI & 90 PSI, OPTIONAL WITH LONGER BODY.
 TEMPERATURE RANGE:
 -22° F (-30° C) TO 175° F (80° C)

Inserta Products, Inc. Blue Bell, Pa. 19422	CHECK VALVE BODIES WITH SUPPORT MEMBER FLANGE TYPE	
--	---	--