



ADACONN®

ADAFLANGE™ ADAPTERS UNIFIED CODE U61 2-BOLT FLANGE TYPE

The **ADAFLANGE™ ADAPTERS, UNIFIED CODE U61 2-BOLT FLANGE TYPE** and the corresponding **FLANGE PORTS** should be a first consideration in any new hydraulic component or system design. Made possible through finite element analysis as part of the CAD design process, this design represents a significant improvement to the current technology.

This design utilizes only two bolts to provide a compact and leak resistant flange connection that meets most hydraulic systems connection needs. **UNIFIED Code U61 4 and 2-Bolt Flange Port** data is in the reference section of this catalog.

The small flange footprint permits adjacent ports to be nested together more closely and efficiently. The two bolt flange mounting holes may be oriented 360 degrees about the central fluid flow axis, and provides maximum flexibility in the design of hydraulic components and integrated hydraulic systems. As the flange fastening is outside the wetted flow area, the structure required to support the internal pressure can be minimized to give a more compact, lighter, leak resistant and economical component and system design.

Industry standard socket head cap screws that meet or exceed the strength requirements of ASTM Standard A574 (minimum tensile strength of 180,000 psi) are used to assemble the **ADAFLANGE™ ADAPTERS**. The data sheet specifies the bolt kits that are recommended with this design. When these adapters are connected to **INSERTA® U61 4 and 2-Bolt Modular Connectors** they offer one the opportunity to make smaller assemblies. This adapter will mate with either of the two diagonal tapped mounting holes of the same nominal size **CODE 61 4-BOLT** flange port.

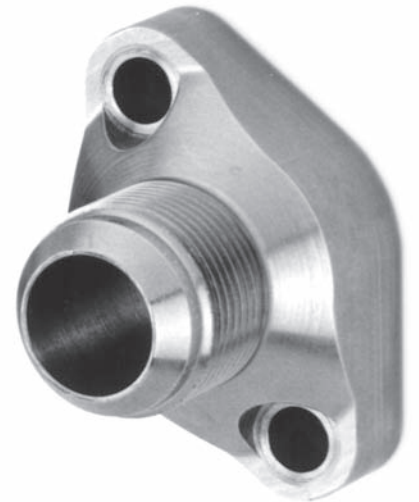

Patent No. 6,467,820

ORDERING INFORMATION

AFO - UK2 16 - F 16 - 2.25 - S 1 - B

**ADACONN®
ADAPTER TYPE**

AFO = ADAFLANGE™

DESIGN

UK2 = UNIFIED CODE U61
2 BOLT MOUNTING PATTERN

FLANGE SIZE

02 = 1/8 08 = 1/2 20 = 1-1/4
04 = 1/4 12 = 3/4 24 = 1-1/2
06 = 3/8 16 = 1 32 = 2

MALE THREAD TYPE

F = 37° FLARE

MALE THREAD SIZE

02 = 5/16 - 24 06 = 9/16 - 18 14 = 1 3/16 - 12 32 = 2 1/2 - 12
03 = 3/8 - 24 08 = 3/4 - 16 16 = 1 5/16 - 12
04 = 7/16 - 20 10 = 7/8 - 14 20 = 1 5/8 - 12
05 = 1/2 - 20 12 = 1 1/16 - 12 24 = 1 7/8 - 12

SEAL MATERIAL

B = BUNA N
V = VITON

ADAPTER FINISH

1 = ZINC CHROMATE

ADAPTER MATERIAL

S = STEEL

ADAPTER LENGTH

2.25 = THE ACTUAL LENGTH
IN INCHES. REF "L" DIMENSION

ADACONN®
Blue Bell, Pa. 19422

ADAFLANGE™ ADAPTERS
UNIFIED CODE U61
2-BOLT FLANGE TYPE

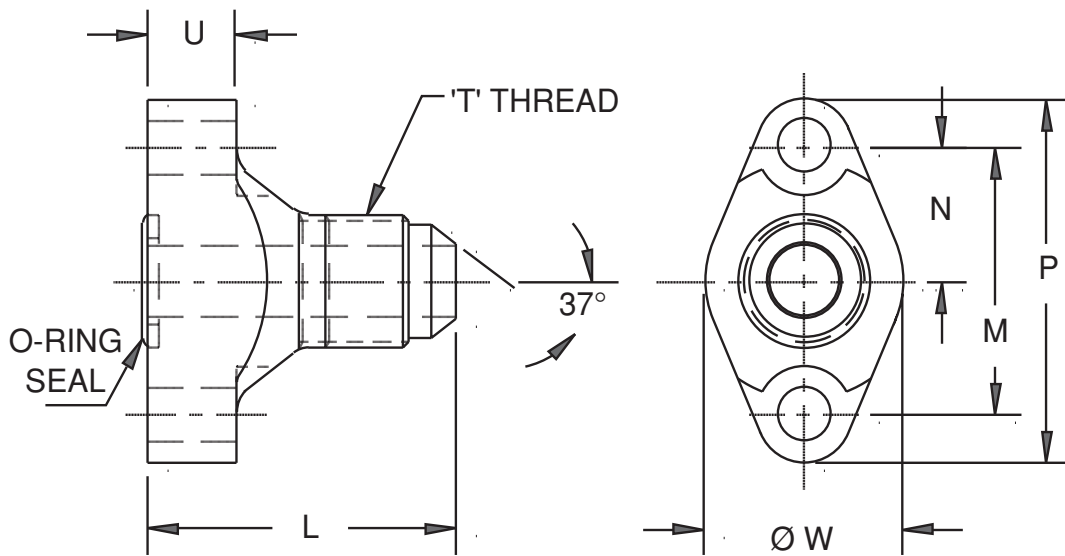

ADAFLANGE™ ADAPTERS UNIFIED CODE U61 2-BOLT

FLANGE SIZE	NOMINAL SIZE	L	M	N	P	T THREAD (UNJF-2A)	U	Ø W	SOCKET HEAD BOLT KIT (2 BOLTS)	O-RING SIZE NO.	Bolt Torque IN-LBS
02	1/8	1.03	.75	.38	1.07	5/16 - 24	.26	.62	ABK-SH2008-32x0.50	010	40/50
02	1/8	1.03	.75	.38	1.07	3/8 - 24	.26	.62	ABK-SH2008-32x0.50	010	40/50
04	1/4	1.19	.88	.44	1.26	7/16 - 20	.33	.75	ABK-SH2010-24x0.63	011	60/75
04	1/4	1.19	.88	.44	1.26	1/2 - 20	.33	.75	ABK-SH2010-24x0.63	011	60/75
06	3/8	1.38	1.12	.56	1.54	9/16 - 18	.40	.87	ABK-SH2025-20x0.87	014	150/170
06	3/8	1.38	1.12	.56	1.54	3/4 - 16	.40	.87	ABK-SH2025-20x0.87	014	150/170
08	1/2	1.75	1.65	.82	2.25	3/4 - 16	.50	1.31	ABK-SH2031-18x1.00	210	250/300
08	1/2	1.80	1.65	.82	2.25	7/8 - 14	.50	1.31	ABK-SH2031-18x1.00	210	250/300
12	3/4	2.12	2.07	1.03	2.73	1 1/16 - 12	.56	1.62	ABK-SH2038-16x1.25	214	400/550
12	3/4	2.12	2.07	1.03	2.73	1 3/16 - 12	.56	1.62	ABK-SH2038-16x1.25	214	400/550
16	1	2.25	2.30	1.15	2.97	1 5/16 - 12	.63	1.87	ABK-SH2038-16x1.25	219	400/550
20	1 1/4	2.31	2.60	1.30	3.36	1 5/8 - 12	.66	2.12	ABK-SH2044-14x1.50	222	750/900
24	1 1/2	2.56	3.09	1.54	3.97	1 7/8 - 12	.66	2.50	ABK-SH2050-13x1.50	225	1400/1600
32	2	2.68	3.49	1.74	4.38	2 1/2 - 12	.66	3.00	ABK-SH2050-13x1.50	228	1400/1600

The Unified Code U61 4 & 2-Bolt Flange Port dimensions are listed on page 52.

These **ADAFLANGE™ Flange Adapters** are also available with end configurations to adapt to other tube, pipe and hose connections as well as in other materials and finishes for customers' quantity requirements.

The bolt kits listed are for fastening the adapters directly to a **UNIFIED Code U61 2-Bolt** flange port. The length of the bolts in the kit are indicated after the x; i.e. 1.25 is 1.25 inches long. These provide a minimum of 1 1/2 times the nominal bolt diameter for thread engagement. Longer lengths need to be considered when other conditions exist such as fastening to lower strength materials. When **INSERTA® MODULES** are stacked between the Flange Port and the **ADAFLANGE™ Flange Adapter**, longer bolts will be required. Changing the last digits of the Bolt Kit part number is required to specify the longer length. Bolt Kit ordering information is provided in this catalog under fastener requirements.

These bolt kits include industry standard 1960 series bolts (Socket Head Cap Screws) that meet the strength requirements of ASTM Standard A574, i.e. minimum tensile of 180,000 PSI.

ADACONN® Blue Bell, Pa. 19422	ADAFLANGE™ ADAPTERS UNIFIED CODE U61 2-BOLT FLANGE TYPE		
-----------------------------------------	----------------------------------------------------------------------	--	--